



1 Door Refrigerated Pizza Prep Table | **AP44**

- Spacious: 10.9 cu ft capacity
- Durable: Stainless steel exterior, painted aluminum interior
- Efficient: Low energy usage (2.89 kW/24h)
- Convenient: Self-closing door, efficient LED lighting
- Certified: ETL Electrical, ETL Sanitation, DOE
- Mobility: Locking casters
- Powerful: 1/6 HP compressor
- Sleek: Stainless steel finish, swing-style solid door



Refrigerant	R290
Horsepower (HP)	1/6
Voltage (V)	115V/60Hz
KW per 24h	2.89 kW/h/24h
Wattage	327
Shipping Weight (lbs)	286.6
Door Self Closed	Yes
Interior Material	Painted Aluminum
Exterior Material	Stainless Steel
Color	Silver
Door Style	Swing
Door Type	Solid
Number of Doors	1
Compressor Location	Rear Mounted
Shelf Capacity (lbs)	85
Plug Type	NEMA 5-15P

Introducing our top-of-the-line one-door commercial pizza prep table, model AP44, built to deliver exceptional performance and reliability for your commercial kitchen. This pizza prep table offers a spacious interior, with precise measurements of 40 inches in width, 26 inches in depth, and 26 1/2 inches in height, providing ample storage with a capacity of 10.9 cubic feet, designed to accommodate all your refrigerated items.

Made with a strong stainless steel exterior and a clean, easy-to-maintain painted aluminum interior, this unit combines durability with a clean and hygienic look. The thick 2-inch insulation, using cyclopentane, ensures excellent temperature control, keeping your products fresh.

Item	Width (Inch)	Depth (Inch)	Height (Inch)
Exterior	44	32 1/4	41 3/4
Interior	40	26	26 1/2

Capacity (Cu Ft)	Number of Shelves
10.9	1

- **Heavy-duty:** Crafted with a robust stainless steel exterior, a pristine painted aluminum interior, and a dependable 304 stainless steel floor
- **Spacious:** Equipped with 1 epoxy-coated shelf, with the capacity to support up to 85 pounds
- **Insulated:** Boasts a substantial 2-inch insulation for optimal temperature retention
- **Powerful:** Driven by an accurate 1/6 HP compressor for superior performance and reliability
- **Efficient:** Low energy consumption with hydrocarbon based natural R290 refrigerant

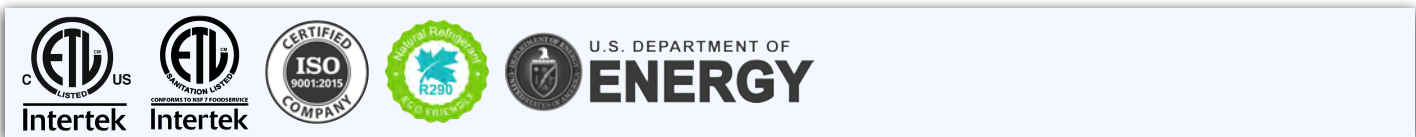

Atlas Air Commercial Refrigeration: info@atlascoolers.com | atlascoolers.com

Note: Specifications subject to change without notice
Do not use in non-commercial or residential settings

Equipped with a sturdy shelf that can hold up to 85 pounds, you'll have plenty of space for your ingredients and items. The built-in LED lighting ensures you can see everything clearly inside.

This pizza prep table is energy-efficient, using eco-friendly R290 refrigerant and powered by a 1/6 horsepower compressor operating at 115V/60Hz. This means it consumes very little energy, costing only 2.89 kW.h/24h, saving you money in the long run.

Hinge Location	Amps (A)	Hertz (Hz)	Temperature Range
Right	3	60	32°F to 40°F
Phase	Plastic Food Pans	Casters	Caster Size (inch)
1	Included	Included	5.75

The **Atlas Air** brand is known for quality, and this pizza prep table lives up to that reputation. Whether you're in the foodservice industry or running a commercial kitchen, you can trust this unit to keep your products at the right temperature, preserving their quality.

1 Door Refrigerated Pizza Prep Table | SKU: AP44

The self-closing door adds convenience and saves energy by ensuring it's always properly sealed. It's easy to move around with four 5 3/4-inch casters that provide stability.



Invest in the future of your business with our AP44 one-door pizza prep table, perfect for your pizza prep needs. It's a powerful, energy-efficient, and reliable addition to any kitchen, designed to meet your needs for years to come. And don't forget to explore our selection of pizza prep tables and other equipment to streamline your pizza-making process.

Technical Data:

FRONT VIEW

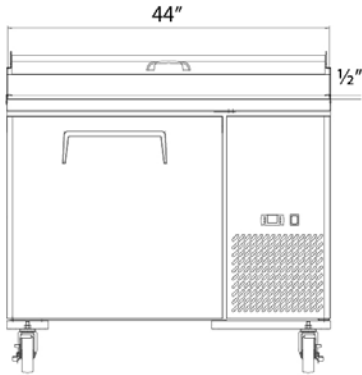

TOP VIEW

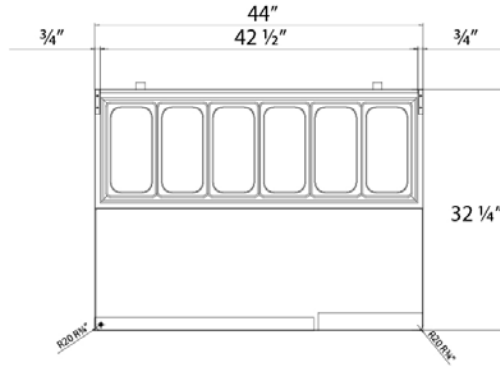

TOP VIEW

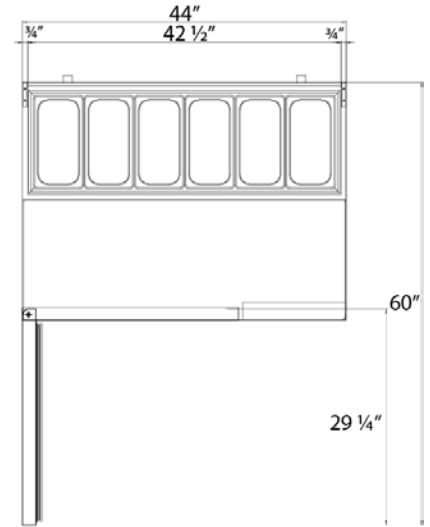

1 Door Refrigerated Pizza Prep Table | SKU: AP44

**Atlas Air's
Comprehensive Warranty:**



SIDE VIEW

